

# FORSITE PE.

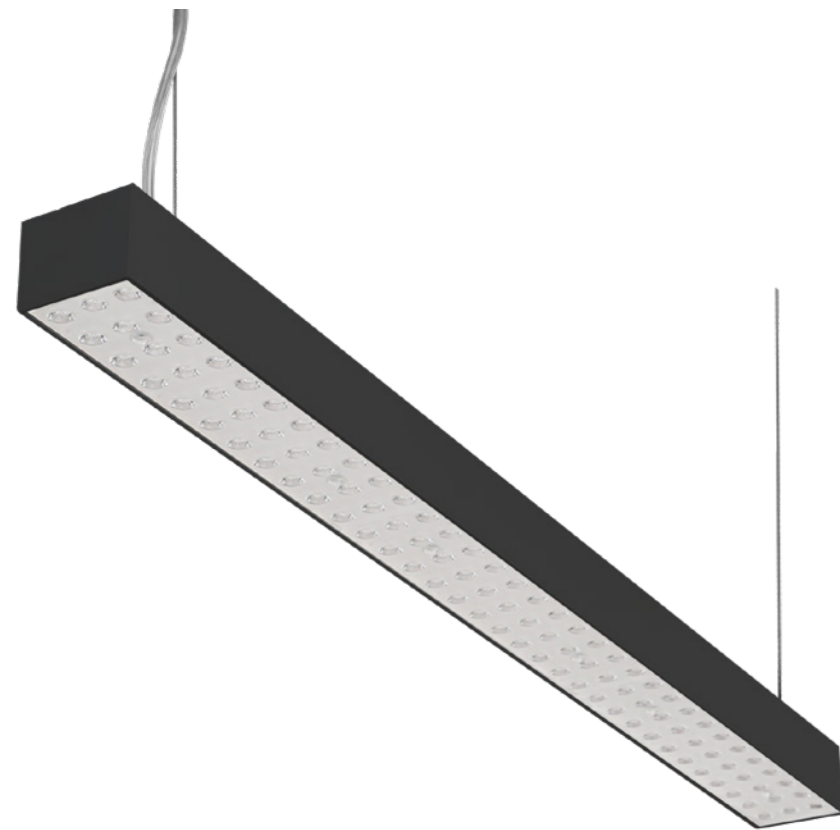

## FORSITE 865 PE.

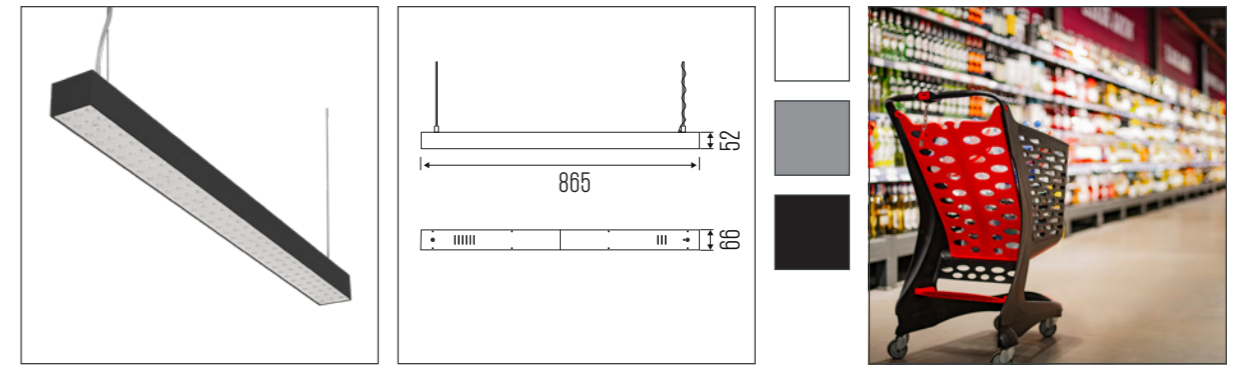

|                         |                      |                          |   |
|-------------------------|----------------------|--------------------------|---|
| CCT                     | : 3000K, 4000K       | Optic                    | : Lens - Double assymetric, 30°,60° and 90° |
| CRI                     | : (RA) >90, (RA) >80 | Mains voltage            | : 220-240V / 50-60Hz                        |
| Chromaticity tolerance  | : 3                  | Max. ambient temperature | : 35°C                                      |
| Luminous flux           | : max. 7300Lm        | Ingress protection       | : IP20                                      |
| Connected load          | : max. 52W           | Net. weight              | : 2.60Kg                                    |
| System efficiency       | : max. 141Lm/W       | Warranty                 | : 5 years                                   |
| Electrical Safety Class | : Class I            |                          |   |

Go to full specs



## FORSITE 1150 PE.

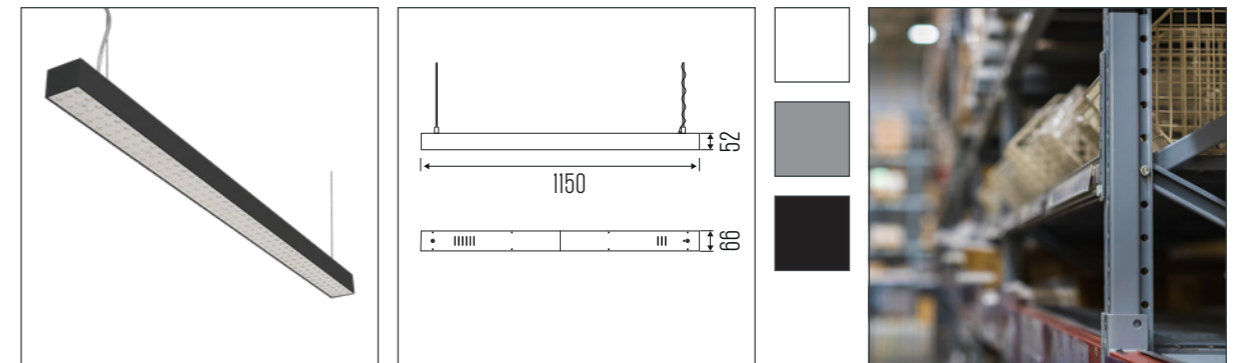

|                         |                      |                          |   |
|-------------------------|----------------------|--------------------------|---|
| CCT                     | : 3000K, 4000K       | Optic                    | : Lens - Double assymetric, 30°,60° and 90° |
| CRI                     | : (RA) >90, (RA) >80 | Mains voltage            | : 220-240V / 50-60Hz                        |
| Chromaticity tolerance  | : 3                  | Max. ambient temperature | : 35°C                                      |
| Luminous flux           | : max. 9750Lm        | Ingress protection       | : IP20                                      |
| Connected load          | : max. 68W           | Net. weight              | : 3.40Kg                                    |
| System efficiency       | : max. 143Lm/W       | Warranty                 | : 5 years                                   |
| Electrical Safety Class | : Class I            |                          |   |

Go to full specs



## STRAIGHT AHEAD.

The suspended version of the Forsite TR. A linear luminaire with everything you need to make a difference in larger areas. Straightforward, powerful and energy-efficient. Choose from a wide beam angle range and the right light colour temperature to create the perfect lighting conditions.

The suspension parts and ceiling cap have to be ordered separately.